

TR-80-R Intelligent Gas Relay

LANSO®

Transformer fittings

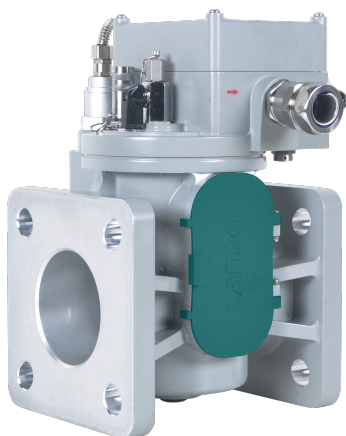

Technical Data

Material of main components: Shell: aluminum alloy
Observation glass: UV resistant protective glass
Working environment: Oil temperature: - 40 °C~+100 °C
Ambient temperature: - 40 °C~+70 °C
Action point properties: Setting range of oil speed alarm: 0.7~2.5m/s, accuracy $\pm 12\%$
Three pairs of dry spring contacts for light and heavy gas alarm (three alarms and three locks)
Electronic auxiliary action point: 1 pair
Installation environment:
protective cover is required for outdoor use
Suitable for high altitude environment
Cable connector: M25X1.5 (for action point), one on both sides of the junction box; 4X0.5 Shielded cable (for remote signal)
Electrical characteristics:
Maximum rated power of action point: 50W (5A),
Maximum switching current: 3A;
Auxiliary action point: Maximum switching power 150W (5A)
Mainboard power supply: 18~36 VDC;
Power frequency withstand voltage: between reed tube contact groups, to ground: 2.5kV DC/AC 1min
Reed contact normally open, auxiliary contact normally open: 1.0kV DC/AC 1min
Analog output: 4~20mA
Digital signal output:
communication protocol ModBus RTU RS-485

Description

Intelligent gas relay is a basic device applied to oil immersed transformer. It can monitor the accumulation of gas generated by leakage current, arc, flashover and other faults in the transformer in real time, and send out alarm signals when the gas reaches a certain amount; In case of serious internal fault of transformer (such as interturn short circuit, etc.), use the oil flow surge phenomenon generated at this time to trigger contact connection, and quickly lock the main circuit of transformer to protect the transformer.

Application

- Up to three alarms, three locks, triple redundancy design, improve product reliability
- It can monitor the volume of gas gas online in real time and transmit it to the background through RS485 digital signal (compatible with 4-20mA analog signal); The external independent gas volume monitoring chamber isolates the interference on the volume monitoring caused by the operation of other components
- The all-metal high-strength movement framework is used to stabilize the flow rate setting value of up to 2.5 m/s
- The float main shaft is equipped with imported precision bearings to increase bearing support and eliminate the hidden danger of wear due to float shaft bore.
- The streamlined float ensures stance stability at high oil speeds
- Protection grade reaches IP67, strong salt spray resistance environment (360 hours NSS salt spray test)

Number of contacts: up to seven pairs, six pairs of dry spring contacts, and one pair of auxiliary changeover contacts

Protection grade : IP67

Electromagnetic compatibility characteristics:

IEC 61000-4-2 Class IV	IEC 61000-4-3 Class III
IEC 61000-4-4 Class IV	IEC 61000-4-5 Class IV
IEC 61000-4-6 Class III	IEC 61000-4-8 Class V
IEC 61000-4-9 Class V	IEC 61000-4-10 Class IV
IEC 61000-4-12 Class III	IEC 61000-4-17 Class III

TR-80-R Intelligent Gas Relay

LANSO[®]
Transformer fittings

Dimensions

